

3500 DC Alternator

Exceeding Military Standards without the Cost

Polar Power, Inc. first tested its DC Alternator using its PMHH technology in 1992. Since then numerous organizations have performed extensive testing on Polar's generators, including the US Army. Polar's DC generator sets (genset) meets both Military and Belcore power applications. Test reports are available. Polar has designed its Model 6200 and 3500 DC alternators incorporating state-of-the-art technologies and all new tooling to meet the increased performance demand for:

- No Maintenance
- No Mechanical Adjustments
- Very High Quality Electrical Output
- Light Weight
- High Efficiency
- High and Low Ambient Operation (-40° to 125° F)
- Adjustable Power Outputs via Engine RPM

Polar Power has met these performance goals through an integrated engineering effort involving detailed analysis of engine, voltage regulator, field coil, magnet, stator, rotor, and diode effects on the system's output voltage and current.

Polar Power selected and optimized the alternator using the Permanent Magnet Hybrid Homopolar

(PMHH) technology. This technology does not require brushes, slip rings, rotating fields, exciters or field flashing. Its small compact design allows use of a bearing-less pancake design.

The PMHH technology is in effect two alternators technologies built into a single simple package. The permanent magnet alternator being the simplest, most efficient and reliable of all the technologies has one drawback in not being able to regulate the voltage output in response to load transients. The homopolar alternator provides the fastest response to load transients among the brush-less alternator technologies. The permanent magnetic portion produces the majority of the output power, the homopolar portion boosts the power produced by the permanent magnet and provides excellent voltage regulation in response to the load transients.

The PMHH technology uses a solid rotor with magnets revolving around a stationary stator and field coil. The construction is extremely simple and requires no maintenance or replacement parts.

To reduce ripple and improve output harmonics, we incorporated a 6 phase stator with each phase rotated 60°. To further improve ripple and output harmonics,

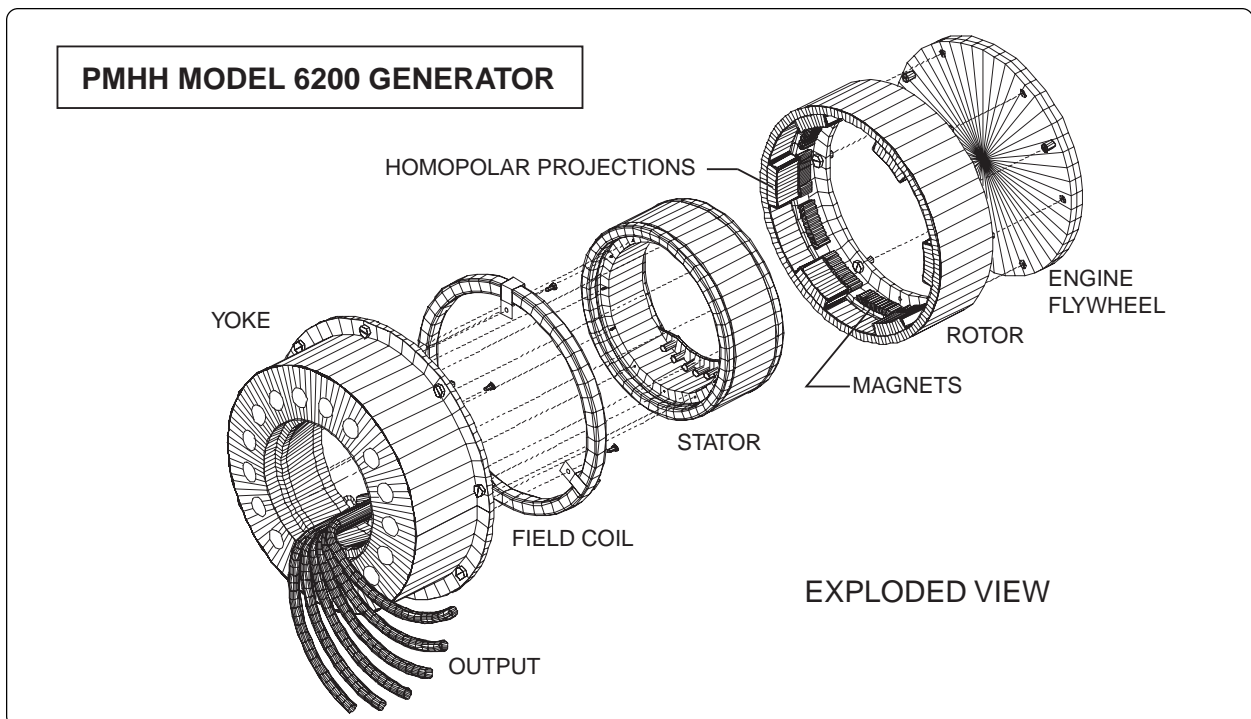

3500 DC Alternator

we used a 12-pole configuration. The voltage regulator incorporates pulse width modulation (PWM) circuitry to provide a true proportional output to the field coil. Most other voltage regulators simply turn the field on/off at lower frequencies, which creates ripple on the generator output.

The 6-phase bridge rectifier assembly has been custom designed to our specifications using the most efficient schottky diodes. The power loss through our 6 phase bridge is less than half that of competitor products.

Engine performance under electrical load is greatly improved due to the 12 poles, 6 phases, and proportional output from the voltage regulator. The engine under these favorable conditions has a smooth and even torque requirement over the 360° flywheel (or shaft) rotation.

Low Maintenance and High Reliability

1. The unique alternator design allows us to turn the engine at low speeds, thereby extending engine life and reducing engine noise.
2. The Model 710 Voltage Regulator has automatic two-step engine speed control. At high electrical load demands the regulator, through an external solenoid, automatically increases engine RPM; at low loads the engine speed is automatically decreased.
3. Polar Power's PMHH alternator has no bearings, couplings, brushes, slip rings, nor rotating fields. There are no alternator parts to wear out.
4. The entire stator assembly is vacuum dipped and baked with a polyester coating. This seals off the metal surfaces from corrosion. Resistance to salt fog is extremely high. The coatings also protect the stator from particle abrasion and vibration.
5. There are no electronic parts (diodes, etc.) nor electrical connections inside the alternator. There is nothing to short or vibrate loose inside the alternator.
6. The alternator is almost impossible to damage electrically. The outputs can be shorted for minutes without damage.
7. The alternator is thermally protected; a sensor on the yoke can alert the operator of a high temperature condition. If no action is taken, the regulator automatically reduces the output current so the alternator can run cooler.
8. The voltage regulator through an external current transducer monitors the output current. The voltage regulator has an adjustable current limit on the output. It is virtually impossible to overload the alternator.
9. Polar Power's PMHH alternator is designed have an MTBF exceeding 100,000 hours, as there are no parts which rub, wear, or overheat under normal operating conditions.
10. The Diode Bridge set is remote from the alternator and mounted on a large heat sink to keep cool and operate under reduced vibration.

MODEL 6200 ALTERNATOR ASSEMBLY CROSS SECTION SIDE VIEW

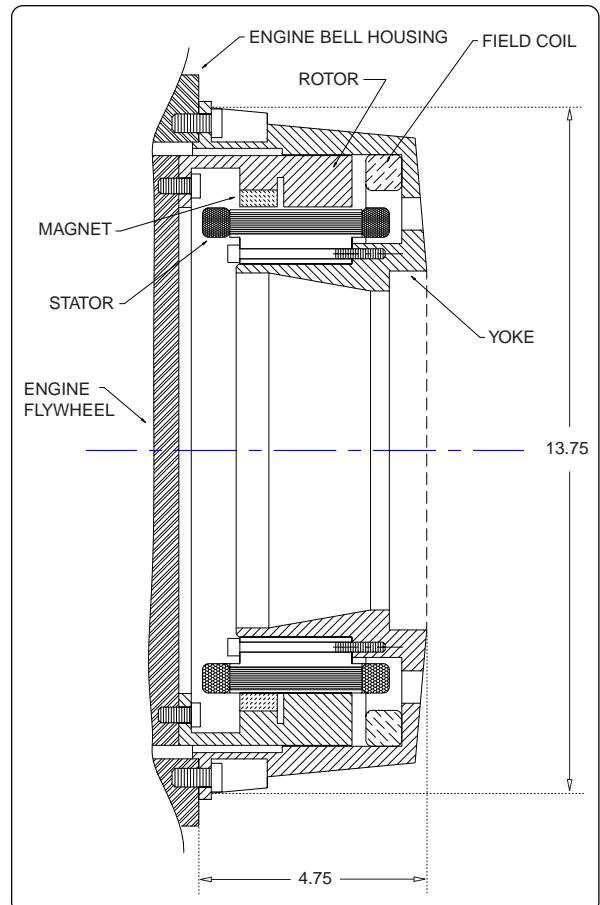

3500 DC Alternator

11. Corrosion is the prime reason most standby generators fail. Polar's alternators are ruggedized for marine and agricultural applications. High humidity, road salt, pesticides can create hostile environments anywhere in the world. All components are constructed of corrosion resistant stainless steel, aluminum, and cadmium plated magnetic steel. Steel laminations are bonded and varnished. Magnets are phenolic coated and bonded with very high temperature resistant epoxy.
13. The alternator's rotor is dynamically balanced to class 3 for improved engine's bearing life.

Very High Quality Electrical Output

Low EMI emissions are designed into the system. There are no brushes or slip rings. Field coil is isolated from the buss through fast diodes and capacitance. The voltage regulator does not strobe the field coil on and off. Proportional control reduces the back EMF produced by the field coil.

1. The 6-phase stator, with each phase placed 60° apart, reduces the amplitude of the current waveform. The 12-pole design also reduces the amplitude of the voltage and current waveforms. The combination of alternator frequency and multiphasing reduces ripple and improves output harmonics.
2. The relatively large iron and copper mass in conjunction with a fast responding voltage regulator reduces the load transient response time to under 200 milliseconds from no load to full load and vice-versa.
3. The voltage regulator maintains the voltage drift too less than 1.5% during a change in ambient temperatures of 60° F over 8 hours.
4. Output ripple is less than 300 millivolts RMS without filter capacitors and without battery on load. With filter capacitors ripple is less than 100 millivolts. Less than 30 millivolts RMS with battery.
5. Distortion factor is less than .01.
6. Voltage regulation from no load to full load is less than 1.5%.
7. Voice frequency noise is less than 40 dB_{BrnC} as measured on the battery.

8. There is an optional load dump built into the voltage regulator to limit the voltage rise transient after a sudden change from full load to no load to under 6 Vdc of set point. The 6 Vdc voltage transient does not last longer than 200 milliseconds. If required, the load dump can be increased to maintain voltage to within 1 Vdc.
9. Voltage adjustment range is 22 to 36 Vdc or 44 to 64 Vdc.

Light Weight

Model 6200 Alternator weighs 83 lbs., including voltage regulator. This is a weight savings of over 160 lbs. over other brushless direct drive alternators. The lightweight can be attributed to the high-energy Neodymium-Iron-Boron magnets, high frequency and "pancake" design.

Low Fuel Consumption for the selected engine

The PMHH alternator has an efficiency of between 75% to 85% versus 45% to 70% for other DC alternators. Efficiency is dependent on speed and load.

Low Acoustic Noise

Improving alternator efficiency reduces the horsepower demand on the engine, which reduces the engine noise. The engine can also operate at slower speeds reducing acoustic noise.

Limited warranty:

Defects in materials and workmanship for a period of two years. Repairs and materials are FOB Carson, California. Extended 10 year warranties and on-site warranty/maintenance available under separate contract.